

Pompe sommergibili
Submersible Pumps
Tauchmotorpumpen
Pompes submersibles
Bombas sumergibles
Dränklar dräneringspump
Rioolwater-drainage pompelpompen
Υποβρύχιες αντλίες
Погружные насосы
潜水污水泵

GXR, GXV

ISTRUZIONI ORIGINALI PER L'USO
OPERATING INSTRUCTIONS
BETRIEBSANLEITUNG
INSTRUCTIONS POUR L'UTILISATION
INSTRUCCIONES DE USO
DRIFT/INSTALLATIONSANVISNINGAR
BEDIENINGSVOORSCHRIFT
ΟΔΗΓΙΕΣ ΧΕΙΡΙΣΜΟΥ
Инструкции по эксплуатации
安装使用手册

Pagina	2	Italiano
Page	8	English
Seite	14	Deutsch
Page	20	Français
Página	26	Español
Sidan	32	Svenska
Pagina	38	Nederlands
Σελίδα	44	Ελληνικά
Стр.	50	Русский
页码	56	中文



 **calpeda**[®]



SUMMARY

1	General information	8
2	TECHNICAL DESCRIPTION	8
3	TECHNICAL FEATURES	9
4	SAFETY	9
5.	TRANSPORTATION AND HANDLING	9
6.	INSTALLATION	10
7.	START-UP AND OPERATION	11
8	MAINTENANCE	11
9	DISPOSAL	12
10	SPARE PARTS	12
11	TROUBLESHOOTING	13
12	ANNEXES	61
12.1	Dimensions and weights	61
12.2	Section	63
	Copy of the declaration of conformity	64

1 GENERAL INFORMATION

Before using the product carefully read the information contained in this instruction manual, the manual should be kept for future reference.

Italian is the original language of this instruction manual, this language is the reference language in case of discrepancies in the translations.

This manual is part of the essential safety requirement and must be retained until the product is finally de-commissioned.

The customer, in case of loss, can request a copy of the manual by contacting Calpeda S.p.A. or their agent, specifying the type of product data shown on the label of the machine (see 2.3 Marking)

Any changes, alterations or modifications made to the product or part of it, not authorized by the manufacturer, will revoke the "CE declaration" and warranty.

This appliance should not be operated by children younger than 8 years, people with reduced physical, sensory or mental capacities, or inexperienced people who are not familiar with the product, unless they are given close supervision or instructions on how to use it safely and are made aware by a responsible person of the dangers its use might entail.

Children must not play with the appliance.

It is the user's responsibility to clean and maintain the appliance. Children should never clean or maintain it unless they are given supervision.

Do not use in ponds, tanks or swimming pools or where people may enter or come into contact with the water.

Read carefully the installation section which sets forth:

- The maximum permissible structural working pressure (Chapter 3.1).
- The type and section of the power cable (Chapter 6.7).

- The type of electrical protection to be installed (Chapter 6.7).

1.1 Symbols

To improve the understanding of the manual, below are indicated the symbols used with the related meaning.



Information and warnings that must be observed, otherwise there is a risk that the machine could damage or compromise personnel safety.



The failure to observe electrical information and warnings, could damage the machine or compromise personnel safety.



Notes and warnings for the correct management of the machine and its parts.



Operations that could be performed by the final user. After carefully reading of the instructions, is responsible for maintenance under normal conditions. They are authorized to affect standard maintenance operations.



Operations that must be performed by a qualified electrician. Specialized technician authorised to affect all electrical operations including maintenance. They are able to operate with in the presence of high voltages.



Operations that must be done performed by a qualified technician. Specialized technician able to install the device, under normal conditions, working during "maintenance", and allowed to do electrical and mechanical interventions for maintenance. They must be capable of executing simple electrical and mechanical operations related to the maintenance of the device.



Indicates that it is mandatory to use individual protection devices.



Operations that must be done with the device switched off and disconnected from the power supply.



Operations that must be done with the device switched on.

1.2 Manufacturer name and address

Manufacturer name: Calpeda S.p.A.
Address: Via Roggia di Mezzo, 39
36050 Montorso Vicentino - Vicenza / Italia
www.calpeda.it

1.3 Authorized operators

The product is intended for use by expert operators divided into end users and specialized technicians. (see the symbols above).



It's forbidden, for the end user, carry out operations which must be done only by specialized technicians. The manufacturer declines any liability for damage related to the non-compliance of this warning.

1.4 Warranty

For the product warranty refer to the general terms and conditions of sale.



The warranty covers only the replacement and the repair of the defective parts of the goods (recognized by the manufacturer).

The Warranty will not be considered in the following cases:

- Whenever the use of the device does not conform to the instructions and information described in this manual.
- In case of changes or variations made without authorization of the manufacturer.
- In case of technical interventions executed by a non-authorized personnel.
- In case of failing to carry out adequate maintenance.

1.5 Technical assistance

Any further information about the documentation, technical assistance and spare parts, shall be requested from: Calpeda S.p.A. (paragraph 1.2).

2 TECHNICAL DESCRIPTION

Single-impeller submersible pumps in chrome-nickel stainless steel, with vertical delivery port.

GXR: with open impeller.

GXV: with free-flow (vortex) impeller.

Motor cooled by the pumped water passing between the motor jacket and the external jacket.

Double shaft seal with oil chamber.

2.1 Intended use

Standard construction

- GXR with open impeller.
For clean or slightly dirty water, with solids in suspension up to 10 mm grain size (12 mm for GXR 12).
- GXV with free-flow (vortex) impeller
For clean or slightly dirty water, with solids in suspension up to 25 mm grain size.
- Maximum liquid temperature: 50 °C (40 °C for single-phase pumps).
- Maximum liquid density: 1100 kg/m³.
- Maximum immersion depth: 5 m (with cable of suitable length).
For outdoor use the power supply cable must have a length of not less than 10 m.

2.2 Improper use

The device is designed and built only for the purpose described in paragraph 2.1.



Do not use in garden ponds, tanks or swimming pools when people are in the water.



The Pump cannot be used in explosive or flammable environments.

Improper use of the device is forbidden, as is use under conditions other than those indicated in these instructions.

Improper use of the product reduces the safety and the efficiency of the device, Calpeda shall not be responsible for failure or accident due to improper use.

2.3 Marking

The following picture is a copy of the name-plate that is on the external case of the pump.

1 Pump type									
2 Delivery									
3 Head									
4 Rated power	1-	XXXXXX							
5 Tension nominale	2-	Q min/max X/X m ³ /h							
6 Nom. motor current	3-	H max/min X/X m							
7 Notes	4-	X kW (XHp) S.F.							
8 Fréquence	5-	220Δ/380Y V3~50Hz							
9 Operation Duty	6-	X/X A							
10 Insulation class	7-	XXXXXX							
11 Weight									
12 Power factor									
13 Rotation speed rpm									
14 Protection									
15 Serial number									
16 Certifications									



3 TECHNICAL FEATURES

3.1 Technical data

Dimensions and weight (paragraph 12.1).

Nominal speed 2900/3450 rpm

Protection IP X8

Supply voltage / Frequency:

- up to 240V 1~ 50/60 Hz

- up to 480V 3~ 50/60 Hz

Check that the mains frequency and voltage correspond to the electrical characteristics shown on the indicator plate.

Sound pressure at minimum immersion depth: < 70 dB (A).

Noise disappears or decreases when the pump is submersed.

Maximum starts/hour: 30 at regular intervals (20 for GXR 12)..

Maximum permissible working pressure up to 20 m (2 bar).

4 SAFETY

4.1 General provisions



Before using the product it is necessary to know all the safety indications.

Carefully read all operating instructions and the indications defined for the different steps: from transportation to disposal.

The specialized technicians must carefully comply with all applicable standards and laws, including local regulations of the country where the pump is sold.

The device has been built in conformity with the current safety laws. The improper use could damage people, animals and objects.

The manufacturer declines any liability in the event of damage due to improper use or use under conditions other than those indicated on the name-plate and in these instructions.



Follow the routine maintenance schedules and the promptly replace damaged parts, this will allow the device to work in the best conditions.

Use only original spare parts provided from Calpeda S.p.A or from an authorized distributor.



Don't remove or change the labels placed on the device.

Do not start the device in case of defects or damaged parts.



Maintenance operations, requiring full or partial disassembly of the device, must be done only after disconnection from the supply.



Pollution of the liquid could occur due to leakage of lubricants.

4.2 Safety devices

The device has an external case that prevents any contact with internal parts.

4.3 Residual risks

The appliance, designed for use, when used in-line with the design and safety rules, doesn't have residual risks.

4.4 Information and Safety signals

For this kind of product there will not be any signals on the product.

4.5 Individual protection devices

During installation, starting and maintenance it is suggested to the authorized operators to consider the use of individual protection devices suitable for described activities.

During ordinary and extraordinary maintenance inter-

ventions, where it is required to remove the filter, safety gloves are required.

GB

Signal individual protection device



HAND PROTECTION
(gloves for protection against chemical, thermal and mechanical risks).

5. TRANSPORTATION AND HANDLING

The product is packed to maintain the content intact. During transportation avoid to stack excessive weights. Ensure that during the transportation the packed cannot move.

The transport vehicles must comply, for the weight and dimensions, with the chosen product (see paragraph 12.1 dimensions and weights).

5.1 Handling

Handle with care, the packages must not receive impacts.

Avoid to impact onto the package materials that could damage the pump.

6 INSTALLATION

6.1 Dimensions

For the dimensions of the device refer to the annex "Dimensions" (paragraph 12.1 Annexes).

6.2 Ambient requirements and installation site dimensions

The customer has to prepare the installation site in order to guarantee the right installation and in order to fulfill the device requirements (electrical supply, etc...).

It's Absolutely forbidden to install the machine in an environment with potentially explosive atmosphere.

6.3 Unpacking



Inspect the device in order to check any damages which may have occurred during transportation.

Package material, once removed, must be discarded/recycled according to local laws of the destination country.

6.4. Installation

The internal diameter of the delivery pipe must never be smaller than the diameter of the pump connection port:

G 1 1/4 for **GXR, GXV**;

G 1 1/2 for **GXR 12**;

ATTENTION: The pump must be lifted and transported using the handle fitted for this purpose and not pulled by the electrical power cable.

Place the pump, with vertical axis, at the bottom of the pit or at the site of installation.

6.5. Stationary installation

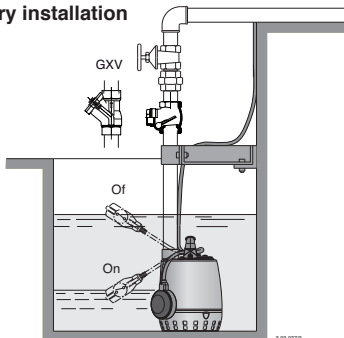

6.5.1. Stationary installation with vertical magnetic float switch

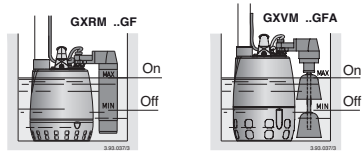

Installation fit a check valve against back flow in the delivery pipe ball valve (swing valve for GXR).

Provide for the possibility of removing the pump without having to drain the entire system (if necessary, fit a gate valve and a union coupling).

With the pump in the resting position secure the delivery pipe to a rest, suitable for its length and weight.

If slime deposits are expected to form at the bottom of the installation pit, a support must be provided to keep the pump raised.

6.6. Transportable installation

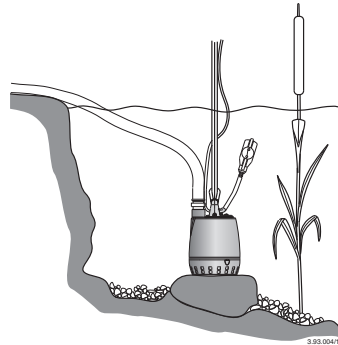

To avoid early deterioration of the pump when used in stagnant water or in rivers, mount on a flat surface raised from the ground so that sand or grit is not lifted.

When a plastic delivery pipe or flexible hose is used, a rope is required for lowering, securing and lifting the pump.

A **safety rope or chain** of non-perishable material should always be used to secure the pump.



Never use the electric power cable to suspend the pump.



In order to avoid the risk of mechanical or electrical injury all portable pumps should be securely isolated from electrical power supply prior to their relocation.

Attach the power supply cable to the delivery pipe or to the safety rope with cable clamps. The power cable should not be taut: allow for a certain degree of slackness to avoid the risk of strain caused by expansion of the pipe during operation.

If you think the sump may dry, drill a 3 mm hole in the delivery pipe before the non-return valve, to allow the air around the rotor to exit par. 12.2. fig. 1.

6.7 Electrical connection



Electrical connection must be carried out only by a qualified electrician in accordance with local regulations.

Follow all safety standards.

The unit must be always earthed, also with a non-metallic delivery pipe.

Make sure the frequency and mains voltage correspond with the name plate data.

For use in swimming pools (not when persons are in the pool), garden ponds and similar places, a residual current device with IAN not exceeding 30 mA must be installed in the supply circuit.

Install a device for disconnection from the mains (switch) with a contact separation of at least 3 mm on all poles.

When extension cables are used, make sure the cable wires are of adequate size to avoid voltage drops and that the connection stays dry.

6.7.1. Single-phase pumps GXR, GXVM

Supplied with incorporated capacitor and thermal protector, with power cable type H07 RN8-F, with plug and float switch.

Connect the plug to a socket with an earth lead.

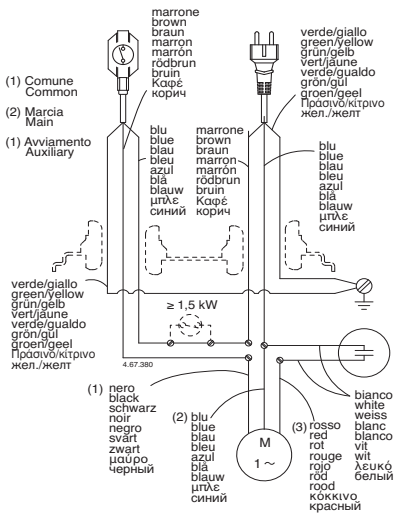

6.7.2. Three-phase pumps GXR, GXV

Cable without plug.

Install in the control box an overload-protective device with curve D in accordance with the name-plate current. With three-phase pumps, when the water level is not under direct visible control, install a float switch connected to the control box and to set the water levels to stop and automatically start the pump.

7 STARTUP AND OPERATION

7.1 Preliminary checks before start-up of the pump

Do not start-up the device in case of damaged parts.

7.2 First starting



With a three-phase power supply make sure the direction of rotation is correct.

Before installation, momentarily start the motor to check through the suction opening that the rotation of the impeller is as shown by the arrow on the pump. Otherwise disconnect electrical power and reverse the connections of two phases in the control box.

Operation with wrong direction of rotation will cause vibration and loss of delivery capacity.

Reverse rotation can also damage the mechanical seal. When in doubt, take the pump out of the water and check rotation of the impeller by sight.

Never introduce fingers in the suction opening unless it is absolutely certain the electric power has been disconnected (that the pump cannot be accidentally switched on) and the impeller has stopped rotating completely.

The motors with supply current directly switched by thermally sensitive switches can start automatically.

Never take the pump out of the water while the pump is still operating.

Avoid running dry.

Construction with float switch: the float switch connected directly to the pump controls starting and stopping. Check that the float switch is free from any obstacle.

Construction without float switch: start the pump only if immersed in the liquid to be raised (see h max paragraph 12.1).

The single-phase motor will stop if operation is prolonged with water at a temperature above 40 °C.

When the windings cool down, the thermal protector enables restarting.

7.3 Switch off of the pump



The appliance must be switch off every time there are faults. (see troubleshooting).

The product is designed for a continuous duty, the switch off is performed by disconnecting the power supply by means the expected disconnecting devices. (see paragraph "6.7 Electrical connection").

8 MAINTENANCE

Before any operations it's necessary to disconnect the power supply.

If required ask to an electrician or to an expert technician.

Every maintenance operations, cleaning or repairation executed with the electrical system under voltage, it could cause serious injuries to people.

A possible replacement of the cable or the level switch must be carried out by an authorised Calpeda service workshop.

If the supply cord is damaged, it must be replaced by the manufacturer, its service agent or similarly qualified persons in order to avoid a hazard.

In case of extraordinary maintenance, or maintenance operations that require part-removing, the operator must be a qualified technician able to read schemes and drawings.

It is suggest to register all maintenance operation executed.

i During maintenance keep particular attention in order to avoid the introduction of small external parts, that could compromise the device safety.

! It is forbidden to execute any operations with the direct use of hands. Use water-resistant, anti-cut gloves to disassemble and clean the filter or in other particular cases.

i During maintenance operations external personnel is not allowed.

Maintenance operations that are not described in this manual must be made only by special personnel authorized by Calpeda S.p.A.

For further technical information regarding the use or the maintenance of the device, contact Calpeda S.p.A.

8.1 Routine maintenance



! Before every maintenance operations disconnect the power supply and make sure that the device could not accidentally operate.

! The pump may have been immersed in hazardous substances or products emanating toxic gases, or may be located in an environment which is toxic due to other reasons; make sure all necessary precautionary measures are taken to avoid accidents.

Any pumps that require inspection/repair must be drained and carefully cleaned inside and outside before dispatch/submission.

Hose down all accessible parts with a jet of water.

If there is a risk of freezing, take the pump out of the water and leave in a dry place.

When used with muddy liquids, run the pump briefly with clean water to remove all deposits immediately after use or before a period of inactivity.

8.2 Dismantling the system

Close the suction and delivery gate valves and drain the pump casing before dismantling the pump.

8.3. Dismantling the pump



For disassembly and reassembly, refer to the cross-section drawing (paragraph 12.2 Annexes).

The pump function can be impaired by erroneous procedure or tampering with internal parts.

To inspect the impeller (28.00), to clean the internal parts and to check whether the impeller turns freely when moved by hand, remove the screws 15.70 or strainer 15.50, the screws (14.24) pump casing (14.00).

To dismantle the impeller remove the nut (28.04).

Others parts should not be dismantled.

8.4. Mechanical seal inspection

If the mechanical seal (36.00) and the oil chamber are to be inspected, follow these instructions.

! CAUTION: there may be slight pressure in the oil chamber.

Care must be taken to avoid a sudden spurting of oil.

Once the plug (34.08) with washer have been removed, adjust the hole to the downward position and empty the chamber completely.

Do not dispose of the waste oil in the enviroment.

The mechanical seal (36.00) can be inspected by removing the screws (70.18).

When re-filling with fresh oil, remember that the chamber must not be completely filled; a sufficient quantity of air must remain inside it in order to compensate for overpressure caused by thermic dilation of the oil.

The quantity of oil to be inserted in the chamber is:

0,04 litres for **GXR, GXV**

0,08 litres for **GXR 12**

Use white oil suitable for food machinery and pharmaceutical use.

9. DISPOSAL



The final disposal of the device must be done by specialized company.

Make sure the specialized company follows the classification of the material parts for the separation.

Observe the local regulations and dispose the device accordingly with the international rules for environment protection.

10 SPARE PARTS

10.1 Spare-parts request

When ordering spare parts, please quote their designation, position number in the cross section drawing and rated data from the pump name plate (type, date and serial number).

! Any pumps that require inspection/repair must be drained and carefully cleaned inside and outside before dispatch/submission.

Hose down all accessible parts with a jet of water.

The spare parts request shall be sent to CALPEDA S.p.A. by phone, fax, e-mail.

Nr. Designation

14.00	Pump casing	70.12	Cable gland ring
14.02	External jacket	70.13	Washer
14.20	Casing gasket	70.16	Cable gland
14.24	Screw	70.17	Lock ring
14.85	Internal pipe	70.18	Screw
14.86	O-ring	70.20	Screw
15.50	Strainer	70.23	O-ring
15.60	Spacer screw	70.32	Washer
15.70	Screw	70.33	Cable gland
28.00	Impeller	70.34	Lock ring
28.04	Impeller nut	73.00	Pump side bearing
28.08	Washer	73.08	V-Ring
28.20	Impeller key	76.02	Kit, motor jacket
34.03	Oil chamber cover	76.60	Float switch
34.08	Plug	76.62	Jacket cover
34.09	O-ring for plug	76.64	Handle
34.12	Screw	76.68	O-ring
34.13	O-ring	78.00	Shaft with rotor packet
36.00	Mechanical sea	81.00	Bearing
36.54	Spacer sleeve	82.02	Screw
40.00	Radial shaft seal	82.03	O-ring
64.08	Shaft sleeve	82.04	Compensating spring
64.12	O-ring	82.05	Screw
64.14	Lower spacer sleeve	94.00	Capacitor
70.00	Motor cover, pump side	96.02	Cable with plug
70.08	O-ring	96.09	Screw
70.09	O-ring	96.12	Cable fastener
70.10	O-ring	96.13	Cable fastener
70.11	Cable gland ring (float switch)		

11. Troubleshooting



WARNING: Turn off the power supply before performing any operations.
Do not allow the pump or motor to run when dry even for a short period
Strictly follow the user instructions and if necessary contact an authorised service centre

PROBLEM	PROBABLE CAUSES	POSSIBLE REMEDIES
1) The engine does not start	1a) Unsuitable power supply 1b) Incorrect electrical connections 1c) Engine overload protective device cuts in. 1d) Blown or defective fuses 1e) Shaft blocked 1f) If the above causes have already been checked, the engine may be malfunctioning	1a) Check that the mains frequency and voltage correspond to the electrical characteristics shown on the indicator plate 1b) Connect the power supply cable to the terminal board correctly. Check that the thermal overload protection is set correctly (see data on the engine indicator plate) and make sure that the fuseboard upline of the engine has been properly connected 1c) Check the power supply and make sure that the pump shaft is turning freely. Check that the thermal overload protection has been set correctly (see engine indicator plate) 1d) Replace the fuses, check the electric power supply and points a) and c) 1e) Remove the cause of blockage as indicated in the "Blocked pump" instruction booklet 1f) Repair or replace the engine by applying to an authorised service centre
2) Pump blocked	2a) Presence of solid bodies in the pump rotor 2b) Bearings blocked	2a) If possible, dismantle the pump casing and remove any solid foreign bodies inside the rotor, if necessary contact an authorised service centre 2b) If the bearings are damaged replace them or if necessary contact an authorised service centre
3) The pump functions but no water comes out	3a) Presence of air inside the pump or suction tube 3b) Suction filter blocked	3a) Release the air from the pump using the pump plugs and/or using the delivery control valve. Repeat the filling operations until all air has been expelled 3b) Clean the filter, if necessary, replace it. See point 2b) also.
4) Insufficient flow	4a) Pipes and accessories with diameter too small causing excessive loss of head 4b) Presence of deposits or solid bodies in the internal passages of the rotor suction filter 4c) Rotor deteriorated 4d) Worn rotor and pump case 4e) Excessive viscosity of the liquid pumped (if other than water) 4f) Incorrect direction of rotation	4a) Use pipes and accessories suitable for the specific application 4b) Clean the rotor and install a suction filter to prevent other foreign bodies from entering 4c) Replace the rotor, if necessary, contact an authorised service centre 4d) Replace the rotor and the pump casing 4e) The pump is unsuitable 4f) Invert the electrical connections on the terminal board or control panel
5) Noise and vibrations from the pump	5a) Rotating part unbalanced 5b) Worn bearings 5c) Pump and pipes not firmly attached 5d) Flow too strong for the diameter of the delivery pipe 5e) Unbalanced power supply	5a) Check that no solid bodies are obstructing the rotor 5b) Replace the bearings 5c) Anchor the delivery and suction piping as needed 5d) Use bigger diameters or reduce the pump flow 5e) Check that the mains voltage is right
6) Leakage from the mechanical seal	6a) The mechanical seal has functioned when dry or has stuck 6b) Mechanical seal scored by presence of abrasive parts in the liquid pumped	In cases 6a), 6b), replace the seal, if necessary contact an authorised service centre 6a) Make sure that the pump casing is full of liquid and that all the air has been expelled. 6b) Use a seal suited to the characteristics of the liquid being pumped.

Changes reserved.

本操作手册属CALPEDA S.P.A.所有，禁止任何形式的复制，即使是部分的。

摘要

1	总则	56
2	技术说明	56
3	技术特性	57
4	安全性	57
5.	搬运操作	57
6.	安装	57
7.	启动和运行	58
8	维修	59
9	处理	59
10	备件	59
11	故障诊断	60
12	附件	61
12.1	尺寸与重量	61
12.2	剖面图	76
	一致性声明	79

1 总则

使用本产品前请仔细阅读此操作手册的内容，并保留此操作手册以供参考。

此操作手册为意大利语，如有翻译偏差以意大利语为准。

此操作手册是安全保障必不可少的一部分，在产品最终达到正常工作前请牢记本手册。

万一用户不慎遗失本手册，可以向CALPEDA S.P.A.或其代理商要求一份复印件，请详述产品铭牌上的资料（见2.3 标记）

未经制造商认可的有关其产品或部件的任何更改变化，将撤消“CE 声明”和质保。

此产品不应让8岁以下的未成年、身体有缺陷、心智不全或无任何经验的人操作，除非在充分的指导或监督下让相关人员知道如何安全的使用，并且通过一个负责人来让相关人员了解到可能会产生的危险。

不得让儿童接触本产品。

用户有义务清洁和维护本产品。除非在有人监督的情况下，否则儿童不应清洁和维护本产品。

不要使用在池塘、水箱或泳池等人为可以进入或接触的水环境中。

仔细阅读安装部分的规定：

-最大允许的结构工作压力详见3.1

-电源线的类型及剖面详见6.7

-所安装电器设备的防护类型详见6.7

1.1 符号标记

为了便于理解本操作手册，下面给出常用标记符号的含义。

 一定要注意警告和警告的标记，否则可能导致产品损坏或人身安全的风险。

 忽略有关电气的警告，可能导致产品损坏或人身安全的风险



提示和警告正确操作处理产品及其部件



最终用户可以进行的操作

终端用户：仔细阅读本操作手册后，产品使用者可以负责正常状态下的维护工作。他们可以进行产品的清洁和长期停滞后的重新启动此类标准维护工作。



必须由有资格的专业电工才能进行的操作

专业电工：有资格的专业电工，负责所有电气设备的运行包括维护，应具有高压电资格。



必须由有专业技术资格的人才能进行的操作

专业技术人员：正常状态下，具有产品安装和维护能力的专业技术人员，可以从事电气和机械方面的维护工作。能够从事简单的与设备维护相关的电气和机械方面的操作。



指示必须使用个别的保护装置



必须断电电源并断开与电源的连接才能进行的操作



必须接通电源才能进行的操作

1.2 制造商名称和地址

制造商名称：CALPEDA S.P.A.

地址：Via Roggia di Mezzo, 39

36050 Montorso Vicentino - Vicenza / Italia

www.calpeda.it

1.3 授权操作者

本产品只能由有经验的终端用户和专业技术人员操作

 禁止终端用户操作那些只能由专业技术人员操作的工作，对未按本规章执行而引起的损害制造商不负任何责任

本设备不适合生理、感官和心智不健全的人员(包括儿童)或缺乏经验和相关知识的人员使用,除非在有专门人员的监管或指导下。

儿童应被监管以避免他们接触此装置。

1.4 质保

质保参见总则和销售条款



质保期内将更换或维修有问题的产品部件（由制造商验证的）。

下面因素不在质保范围：

- 由于产品使用者没有按照说明及本手册的通告信息操作造成的损坏
- 未经制造商认可的对产品的任何改变而造成的损坏
- 由非专业人员操作造成的损坏
- 由不当的维修造成的损坏

1.5 技术支持

任何技术支持、备件及更多的产品信息均可联系：

Calpeda S.p.A. (附件1.2章)。

2 技术说明

單段葉片不鏽鋼水泵浦，垂直方向出水口

GXR: 開放式葉片

GXV: 渦流式葉片

以泵浦所輸送並流經馬達外殼及外部套筒之液體冷卻馬達。

注油室雙層機械軸封

2.1 预期用途

标准结构

-GXR带有开放式叶轮。

适用清水或轻度污水,固体悬浮颗粒可达10mm (12毫米GXR12)

-GXV带有自由流(涡流)叶轮。

适用清水或轻度污水,固体悬浮颗粒可达25mm。

-最高液体温度:50°C (40 °C 单相泵)

-最高液体密度:1100kg/m³

-最高安装深度:5m(带有适当长度的电缆)。

室外安装使用时供电电缆不应小于10m。

2.2 不当使用

本产品只用于2.1中所述用途



当有人在水中时禁止在花园的池塘中,水槽,或者游泳池中使用。



泵不能用于易爆或易燃环境。

除了本说明手册中指示的用途外,严禁其他不当用途

不当使用将降低本产品的安全性和效率,由于不当使用而造成的损坏和意外,CALPEDA不承担责任

2.3 标记

下面给出的是泵壳上的标牌的图片

1 泵型	1- XXXXXXXX	16
2 流量	2- Q min/max XX m ³ /h	15
3 扬程	3- H max/min XX m	14
4 额定功率	4- X kW (Xp) S.F.	13
5 电压 / 相 / 频率	5- 220/380V V3~50Hz	12
7 注释	7- IP XX	11
8 频率	8- cos φ X	10
9 运行工作制	9- XXXXXXXX	9
10 绝缘等级	10- S1	8
11 重量	11- I.c.l. X X kg	8
12 功率因数		
13 转速		
14 保护等级		
15 序列号a		
16 认证		

3 技术特性

3.1 技术参数

尺寸和重量 (见12.1)

额定转速 2900/3450rpm

保护等级 IPX8

电压/频率:

- 高达 240V 1~50/60 Hz

- 高达 480V 3~50/60 Hz

检查主电源的电压、频率等参数是否符合电机铭牌所示

最小浸入深度时噪音等级: < 70 dB (A)。

当水泵完全浸入时,噪音会消失。

最大启动次数/小时: 30次/小时 (间隔均匀时) (20

大于GXR12)。

最大工作压力为 20 m (2 bar)

4 安全性

4.1 总则



使用本产品前应了解有关安全的指示
仔细阅读所有的操作说明和从搬运到处理的每一步指示专业技术人员必须认真遵从所有的适用标准和法律,包括产品应用地当地的规章
产品安装使用应符合现行的安全法规
不当的使用可能会对人身、动物和其他对象造成损害
制造商对由于不当使用或未按本操作手册和标牌的标示使用所造成的损坏不负责任



按照日程维护计划表操作并及时更换损坏的部件
可使产品工作在最佳状态
使用CALPEDA S.P.A或其指定代理商提供的原厂配件



不要撕下或改变产品上的标识

当产品有问题或部件有损坏的情况下不要启动产品



由于维修时会全部或部分的拆开产品,因此之前务必要断开供电电源



润滑剂的泄漏会引起液体污染。

4.2 安全装置

本产品具有全外部壳体,可防止与内部部件的任何接触

4.3 剩余风险

当按照本产品的设计功能和所有安全规则使用本产品时没有剩余风险

4.4 通告和安全预示

没有任何安全预示在此类产品上面

4.5 个别的保护装置

在安装、使用和维修期间,建议操作人员使用适合此操作的个别保护装置或手段

当进行日常或个别的维修工作时,拆过滤器时应带手套

标示的个别保护装置



手的保护

(防热、化学品和机械损害的手套)

5. 搬运操作

货物应包装完好

运输过程中应避免超重,并确保货物不会移动。确保

运输车辆和所运货物尺寸相符合

无需特殊车辆运输

运输车辆应与被运货物的尺寸重量相符合 (见表见

12.1 尺寸与重量)

5.1 搬运

小心搬运,轻拿轻放

避免冲撞包装材料以免损坏泵的外套

6 安装

6.1 尺寸

产品的尺寸详见附件“尺寸”(附件12.1章)

6.2 环境要求和安装位置的尺寸

客户应将本产品适当的安装于适当位置以满足设备的要求 (供电需要等)

禁止将产品安装于有潜在易燃易爆危险的环境中

6.3 拆箱



开箱检查产品是否因运输而损坏

拆开的包装材料应根据产品使用国当地的法律规定遗弃或再利用

缓慢提升泵-电机组(见12.2章节图1)

确保它不会晃来晃去,以避免因不平衡而倾倒。

6.4. 安装

出水管内径绝不允许小于泵的出水口尺寸:

G 1 1/4 适用于 GXR, GXV;

G 1 1/2 适用于 GXR 12.

警告: 水泵的提升和运输必须使用手柄, 绝不能用电缆拉拽。

放置水泵时,必须垂直安放于井底或其他安装位置的底部。

6.5. 固定安装。

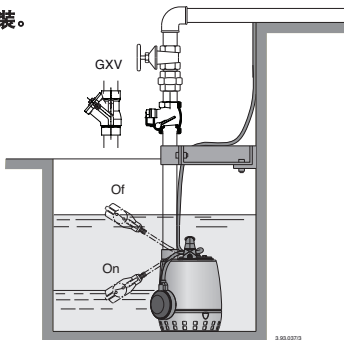

6.5.1 带有垂直电磁浮子开关的泵的固定安装。

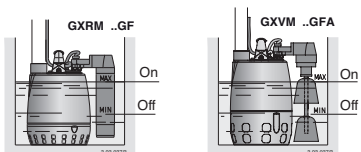

应安装一止回阀以防止泵出水管的水倒流。应提供不必排空整个系统而可以移动泵的可能性（最好安装一个闸阀和连接接头）。当把泵安装在安置地点时，应确保出水管路有适合其长度与重量的支撑。如果安放位置的底部可能会有污泥时，则必须提供一个支撑以确保泵能直立。

中文

6.6. 移动式安装

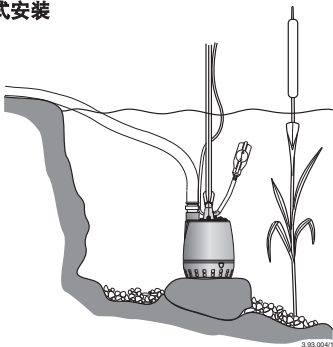

为避免泵过早的损坏，当在死水或江河中使用，应将泵安置于高出底部一些的地方，以避免细沙被吸入。当出水管为塑料管或软管时，应用绳索来升降和固定水泵。用防腐的绳子或链子来系住水泵以确保其安全。

绝不允许用电缆悬系泵。



为避免机械电气损坏的危险，所有此类便携式泵在移动之前必须断开主电源。电源电缆可以用卡子卡在出水管上或安全绳上，电缆不应被拉紧而应该有一定程度的，以避免在工作中由于管道的膨胀引起应力的危险。当污水坑有干涸的可能时，可在止回阀前的出口管路上钻一个3mm的孔，以允许转子间的空气排出 章12.2.图.1.

6.7. 电气联接



必须由合格电工根据当地规范进行电气联接。
必须遵守安全标准。

泵组必须保持接地，出水管必须是非金属确保频率和主电压与铭牌上标的相符。

当泵用于游泳池中（开泵时池中不得有人），花园池塘和类似的地方时，在供电回路中必须安装漏电保护装置，灵敏度不超过30MA。

安装电源的断路器，各级之间距离不小于3MM。

当需要加长电缆时，确认电线是合适的型号以避免电压下降，同时注意连接处的防水。

6.7.1. 单相泵 GXRM, GXVM

提供内置电容和热保护器，带动力电缆型号H07 RN8-F，带有插头和漂浮开关。连接插头到带地线的插座。

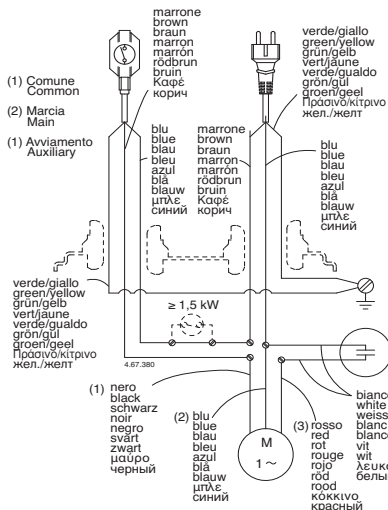

6.7.2. 三相泵 GXR, GXV

不带插头的电缆。

根据铭牌上的电流在控制箱中安装一过载保护曲线 D 器。

对于三相泵，当不可能根据目视对水面进行控制时，安装一漂浮开关并连接至控制盒，以实现根据水面的高低自动起、停泵。

7 启动和运行

7.1 启动前的预检

当存在有故障的部件时不要启动本产品

7.2 首次启动



对于三相供电的情况应确保电机旋转方向正确。

在安装之前，瞬时启动电机通过水泵进水口检查叶轮的转向是否与泵的肩头标识一致。

否则切断电源，交换控制箱中两极的连接。
错误的旋转方向的运行将导致震动和出口流量的损失。
相反的旋转方向也会损坏机械密封。
对电机的转向有疑问时，把泵从水下取出，用肉眼检查叶轮旋转方向。

警告：千万不要将手指塞入泵的进水口内，除非绝对肯定电源已被切断（同时肯定不会意外的接通），并必须肯定叶轮已完全停止旋转。
接好的电机可能被热敏开关直接接通而自动运行起来。
千万不要将正在工作的泵从水中取出。
绝对禁止干转。

漂浮开关的结构：直接与泵连接的漂浮开关控制泵的启动和停止。
检查漂浮开关是否能不受阻碍的自由运动。

不带漂浮开关的结构：
只有当泵完全浸入液体中时才能启动(附件12.1章)。
单相泵在水温超过40度时持续运转将自动停止工作。
当绕组冷却后，热保护将允许电机重新启动。

7.3 泵的停车



警告：当存在故障时必须关闭设备

本产品设计为连续工作，当希望断开本产品时可断开供电电源(见章节6.8 电气连接)

8 维修

任何维修操作前都应该先断开电源,必要时可由电工或专业技术人员操作

警告：在带电情况下的任何类似清洁或维修的操作都可能对人身造成严重伤害

警告：如果电源电缆出现损坏，必须由厂商、厂商代理或相同资质的人员进行更换

警告：如果电源线损坏，为避免危险发生，新配件必须由供应商提供并更换。

突发的维修或需要部分拆解零件的维修,都必须由能看懂结构图的专业人员来操作

警告：建议记录所有的维修过程,在维修期间特别小心注意不要带入任何外部细小异物,这会对产品的造成损害

警告：不要在无防护措施的情况下用手直接操作，应带防水防割的手套进行过滤器的拆解清洁或其他维修工作

警告：维修期间无关人员禁止入内

本操作手册中没有介绍的维修工作只能由CALPEDA授权的特别人员来完成
有关产品使用和维修的更多信息请联系CALPEDA S.P.A.

8.1 日常维护



警告：每次维修工作前都应先断开电源并确保设备不会意外接通运转

警告：当泵可能浸入过有毒的或会放出有毒气体的物质中，或曾放置在因其他原因而有毒的环境中时，应确保采取一切必要的预防措施，以避免意外的发生。

任何需要检查/维修的泵在发货前均应将泵内水排干，并仔细清洁泵的内、外部。

喷水冲洗所有可见的零部件
如果有结冰的危险，将泵从水中取出放置在干燥的地方。
当应用于泥泞液体时，使用过后或闲置之前，应马上用清水短暂运行一下泵，以除去泵内的附着物。

8.2 系统的分解

分解前，关闭进出口隔栅。

8.3. 泵的拆解



在拆卸和重新组装前，参看剖面图第(附件12.1章)。

对内部零件的错误操作和处理将损伤泵的功能。

检查叶轮 (28.00),清洁内部零件并检查叶轮是否可用手自如的转动,依次拆下螺丝(15.70) 或过滤器(15.50), 螺丝(14.24)和泵壳(14.00).
拆下叶轮螺母(28.04)拆下叶轮。
其他零部件可不拆,

8.4. 机械密封的检查。

如果机械密封(36.00)和油室可以观察到,应遵循下列步骤:

警告：油室中可能有轻微的压力。
小心避免油突然喷出。

T一旦卸下水堵(34.08)和垫片,请将孔调整到向下的位置,并将油室彻底排空。
不要将废油排放到周围环境中去。
拆下螺丝(70.18)检查机械密封(36.00).

当重新加注新油时,应记住不能完全充满油室,室内要保留一定量空气,以便补偿由于油受热膨胀而造成的超压。

室内装入油的体积:
0.04升对GXR, GXV.
0.08升对GXR 12.

请使用适合于食品机械和医药工业用的白油。

9. 处理



产品的最终处理应由专业公司操作
确保专业公司是按照材料分类方式处理
按照当地的法规和有关环境保护的国际准则处理

10 备件

10.1 订购备件

订购备件时请根据剖面图提供备件的名称和位置编号及泵铭牌上的数据(型号、参数和序列号)

警告：任何需要检查/维修的泵在发货前均应将泵内水排干，并仔细清洁泵的内、外部。
喷水冲洗所有可见的零部件。
备件需求请电话、传真、邮件给CALPEDA S.P.A

Nr. 名称

- 14.00: 泵壳
- 14.02: 外壳
- 14.20: 壳体垫圈
- 14.24: 螺栓
- 14.85: 内管
- 14.86: O型圈
- 15.50: 过滤器
- 15.60: 垫片螺钉
- 15.70: 螺丝
- 28.00: 叶轮
- 28.04: 叶轮螺母
- 28.08: 垫片
- 28.20: 叶轮键
- 34.03: 油室盖
- 34.08: 堵
- 34.09: 垫片
- 34.12: 螺栓
- 34.13: O型圈
- 36.00: 机械密封
- 36.54: 隔离套
- 40.00: 径向轴封
- 64.08: 轴套
- 64.12: O型圈
- 64.14: 下隔套
- 70.00: 泵侧电机盖
- 70.08: O型圈
- 70.09: O型圈
- 70.10: O型圈(漂浮开关)
- 70.11: 电缆密封圈(漂浮开关)
- 70.12: 电缆密封圈
- 70.13: 垫圈
- 70.16: 电缆管
- 70.17: 锁环
- 70.18: 螺栓
- 70.20: 螺栓
- 70.23: O型圈
- 70.32: 垫圈(漂浮开关)
- 70.33: 电缆管
- 70.34: 锁环
- 73.00: 泵侧轴承
- 73.08: V型圈
- 76.02: 电机壳内套件
- 76.16: 支撑
- 76.60: 漂浮开关
- 76.62: 壳盖
- 76.64: 手柄
- 76.68: O型圈
- 78.00: 轴与转子组
- 81.00: 轴承
- 82.02: 螺栓
- 82.03: O型圈
- 82.04: 补偿弹簧
- 82.05: 螺栓(1)
- 94.00: 电容
- 96.02: 带插头的电缆
- 96.09: 螺栓
- 96.12: 线夹子
- 96.13: 线夹子

11. 常见故障和解决方法



警告: 任何操作之前均应断开电源。
决不允许泵组干转,即使是短时间的。
严格按照使用说明书操作,如有必要请联系授权服务中心。

故障现象	故障的可能原因	解决办法
1) 电机不转	1a)供电问题 1b)电线连接错误 1c)电机的过载保护动作 1d)保险丝问题 1e)泵轴卡死 1f)如以上问题均检查过而故障仍存在,可能是电机问题	1a)检查主电源的电压、频率等参数是否符合电机铭牌所示 1b)检查电源到接线盒的连线是否正确,检查热保护装置的设置是否正确(见电机铭牌上的数据),确认保险丝连接正确 1c)检查供电电源并确认泵轴可以自由转动,检查过热保护装置是否正确设置(见电机铭牌数据) 1d)更换保险丝,并检查主电源同时见a)c) 1e)见2)泵卡死 1f)向本地服务中心申请维修或更换电机
2 泵卡死不转	2a)泵轴转动部分有异物卡住 2b)轴承损坏	2a)如果可能,拆开泵壳并取出卡阻物.如有必要可以联系本地服务中心解决 2b)如果轴承已损坏更换它,或联系本地服务中心解决
3) 泵工作但不出水	3a)泵内或吸入管路内有空气 3b)进口处过滤器堵塞	3a)通过泵加水堵或出口控制阀放气,重新灌泵直至空气完全排出 3b)清洗过滤器,如有必要更换它。同时参见2b
4) 流量不足	4a)管路或附件直径过小导致过多的损失 4b)吸入口过滤器通道内有异物或沉积物堵塞 4c)转子老化损坏 4d)转子和泵壳磨损严重 4e)泵送的液体粘度过高(非水) 4f)反转	4a)选用直径适当的管路和附件 4b)清洁转子并安装一进口过滤器以防异物进入 4c)更换转子,如有必要联系本地服务中心解决 4d)更换转子和泵壳 4e)选泵不合适 4f)将接线盒内或控制柜内任意两线对调
5) 泵的震动和噪音	5a)转动部件不平衡 5b)轴承磨损严重 5c)泵和管路没有稳固的连接固定 5d)针对所使用的出口管路而言流量过大 5e)三相电不平衡	5a)检查是否有异物卡住转轴 5b)更换轴承 5c)牢固连接固定进水管路 5d)换用更粗的出水管或减小泵的流量 5e)检查主电源
6) 机封漏水	6a)机封干转或粘连而失效 6b)泵送液体内有腐蚀性物质导致机封划伤	对6a) 6b)的情况,更换机封,如有必要请联系本地服务中心解决 6a)确认泵壳内已充满液体,气体已被完全排出 6b)选用与所泵送介质特性相符合的机封

保留更改权利

中文

12. ALLEGATI

12.1 Dimensioni e pesi, Dimensions and weights Abmessung und Gewicht, Dimensions et poids Dimensiones y pesos, Mått och vikt Αφμετινεν εν gewicht, Διαστάσεις και βάρη Габариты и вес, 尺寸与重量 GXR, GXV 25

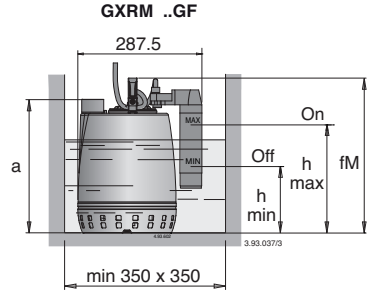
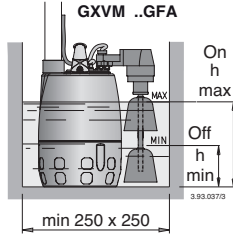
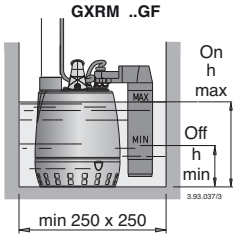

TYPE	mm		
	H	h min	h max
GXR 9 GF	265	100	190
GXR 11 GF	300	135	225
GXR 13 GF	300	135	225
GXVM 25-6 GFA	302	70	150
GXVM 25-8 GFA	337	70	185
GXVM 25-10 GFA	337	70	185

	mm			
	fM	a	h min	h max
GXR 12-10 GF	360	310	180	270
GXR 12-12 GF	375	325	195	285
GXR 12-14 GF	400	350	220	310
GXR 12-16 GF	400	350	220	310

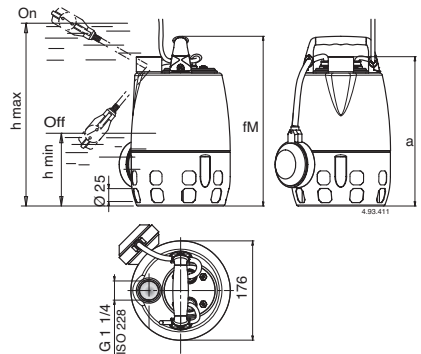
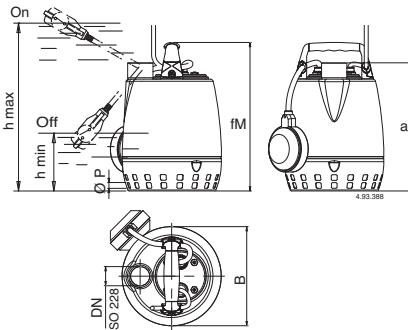

TYPE	mm								kg (1)		
	DN	Ø P	B	fM	a	h max	h min	GXR	GXRM	GXV	GXVM
GXR(M) 9	G 1 1/4	10	176	265	230	340	70	5	5,2		
GXR(M) 11	G 1 1/4	10	176	300	265	340	70	6,2	6,5		
GXR(M) 13	G 1 1/4	10	176	300	265	340	70	6,7	7,2		
GXR(M) 12-10	G 1 1/2	12	228	360	310	435	175	10,3	11,3		
GXR(M) 12-12	G 1 1/2	12	228	375	325	450	190	11,5	12,5		
GXR(M) 12-14	G 1 1/2	12	228	400	350	475	215	13	14		
GXR(M) 12-16	G 1 1/2	12	228	400	350	475	215	13,6	14,6		
GXR(M) 12-18	G 1 1/2	12	228	420	370	495	235	14,4	15,9		
GXR(M) 12-20	G 1 1/2	12	228	450	400	525	265	16	17,5		

TYPE	mm				kg (1)	
	fM	a	h max	h min	GXV	GXVM
GXR(M) 25-6	302	267	375	130	5,1	5,3
GXR(M) 25-8	337	302	375	130	6,3	6,6
GXR(M) 25-10	337	302	375	130	6,8	7,3

(1) Con cavo
With cable

(1) Con cavo
With cable

12. ALLEGATI

12.1 Dimensioni e pesi

Dimensions and weights
Abmessung und Gewicht
Dimensions et poids
Dimensiones y pesos
Mått och vikt
Afmetingen en gewicht
Διαστάσεις και βάρη
Габариты и вес
尺寸与重量
GXR-R

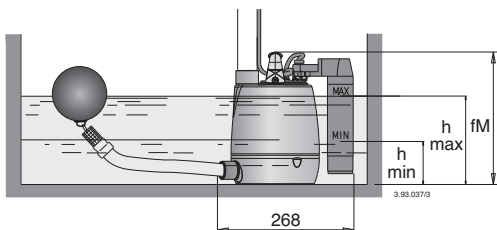

TYPE	mm			(1) kg
	fM	h min	h max	
GXR-RM 9 GF	265	100	190	5,2
GXR-RM 11 GF	300	135	225	6,5
GXR-RM 13 GF	300	135	225	7,2

(1) Con cavo
With cable

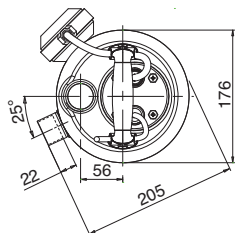
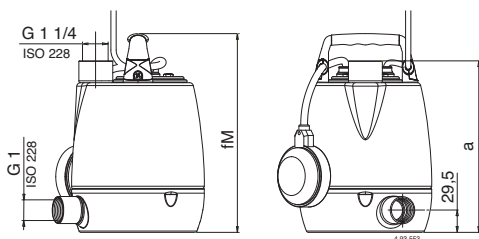
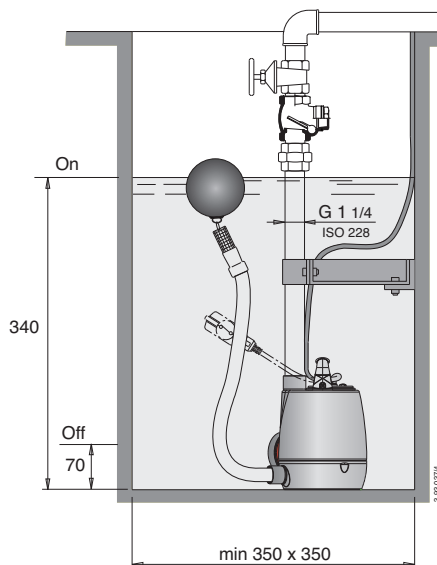

TYPE	Dimensions mm		(1) kg	
	fM	a	GXR-R	GXR-RM
GXR-R 9 - GXR-RM 9	265	230	5	5,2
GXR-R 11 - GXR-RM 11	300	265	6,2	6,5
GXR-R 13 - GXR-RM 13	300	265	6,7	7,2

(1) Con cavo
With cable

12.2. Disegno per lo smontaggio ed il rimontaggio
Drawing for dismantling and assembly
Zeichnung für Demontage und Montage
Dessin pour démontage et montage
Dibujo para desmontaje y montaje
Ritning för demontering och monterning
Onderdelentekening
Чертеж для демонтажа и сборки
组装与分解图
GXR, GXV 25

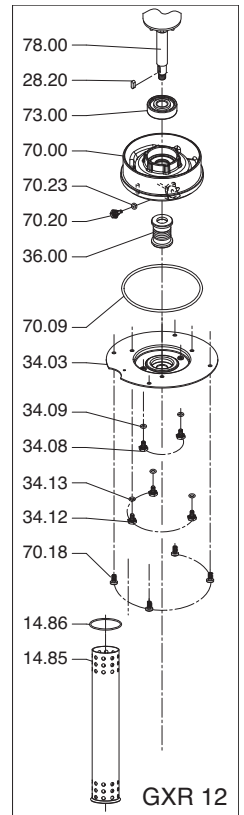
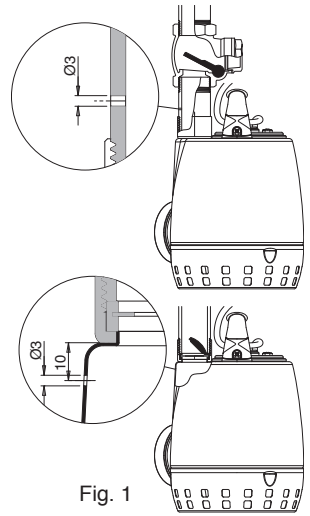
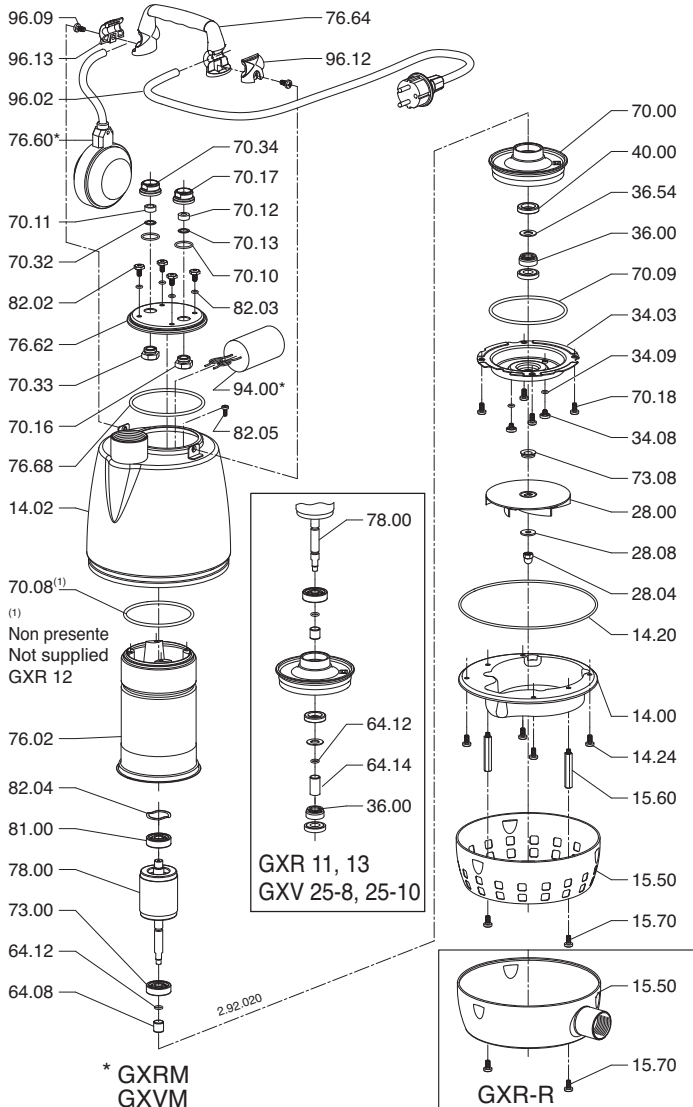

I DICHIARAZIONE DI CONFORMITÀ

Noi CALPEDA S.p.A. dichiariamo sotto la nostra esclusiva responsabilità che le Pompe GXR, GXV, GXR-R, GXRM, GXVM, GXR-RM, tipo e numero di serie riportati in targa, sono conformi a quanto prescritto dalle Direttive 2006/42/CE, 2014/30/EU, 2014/35/EU e dalle relative norme armonizzate.

GB DECLARATION OF CONFORMITY

We CALPEDA S.p.A. declare that our Pumps GXR, GXV, GXR-R, GXRM, GXVM, GXR-RM, with pump type and serial number as shown on the name plate, are constructed in accordance with Directives 2006/42/EC, 2014/30/EU, 2014/35/EU and assume full responsibility for conformity with the standards laid down therein.

D KONFORMITÄTSEERKLÄRUNG

Wir, das Unternehmen CALPEDA S.p.A., erklären hiermit verbindlich, daß die Pumpen GXR, GXV, GXR-R, GXRM, GXVM, GXR-RM, Typbezeichnung und Fabrik-Nr. nach Leistungsschild den EG-Vorschriften 2006/42/EG, 2014/30/EU, 2014/35/EU entsprechen.

F DECLARATION DE CONFORMITE

Nous, CALPEDA S.p.A., déclarons que les Pompes GXR, GXV, GXR-R, GXRM, GXVM, GXR-RM, modèle et numero de série marqués sur la plaque signalétique sont conformes aux Directives 2006/42/CE, 2014/30/EU, 2014/35/EU.

E DECLARACION DE CONFORMIDAD

En CALPEDA S.p.A. declaramos bajo nuestra exclusiva responsabilidad que las Bombas GXR, GXV, GXR-R, GXRM, GXVM, GXR-RM, modelo y numero de serie marcados en la placa de características son conformes a las disposiciones de las Directivas 2006/42/CE, 2014/30/EU, 2014/35/EU.

DK OVERENSSTEMMELSEERKLÆRING

Vi CALPEDA S.p.A. erklærer hermed at vore pumper GXR, GXV, GXR-R, GXRM, GXVM, GXR-RM, pumpe type og serie nummer vist på typeskiltet er fremstillet i overensstemmelse med bestemmelserne i Direktiv 2006/42/EC, 2014/30/EU, 2014/35/EU og er i overensstemmelse med de heri indeholdte standarder.

P DECLARAÇÃO DE CONFORMIDADE

Nós, CALPEDA S.p.A., declaramos que as nossas Bombas GXR, GXV, GXR-R, GXRM, GXVM, GXR-RM, modelo e número de série indicado na placa identificadora são construídas de acordo com as Directivas 2006/42/CE, 2014/30/EU, 2014/35/EU e somos inteiramente responsáveis pela conformidade das respectivas normas.

NL CONFORMITEITSVERKLARING

Wij CALPEDA S.p.A. verklaren hiermede dat onze pompen GXR, GXV, GXR-R, GXRM, GXVM, GXR-RM, pomptype en serienummer zoals vermeld op de typeplaat aan de EG-voorschriften 2006/42/EU, 2014/30/EU, 2014/35/EU voldoen.

SF VAKUUTUS

Me CALPEDA S.p.A. vakuutamme että pumppumme GXR, GXV, GXR-R, GXRM, GXVM, GXR-RM, malli ja valmistusnumero tyypikivulvstä, ovat valmistettu 2006/42/EU, 2014/30/EU, 2014/35/EU direktiivien mukaisesti ja CALPEDA ottaa täyden vastuun siitä, että tuotteet vastaavat näitä standardeja.

S EU NORM CERTIFIKAT

CALPEDA S.p.A. intygar att pumpar GXR, GXV, GXR-R, GXRM, GXVM, GXR-RM, pumptyp och serienummer, visa de på namnplåten är konstruerade enligt direktiv 2006/42/EC, 2014/30/EU, 2014/35/EU. Calpeda åtar sig fullt ansvar för överensstämmelse med standard som fastställts i dessa avtal.

GR ΔΗΛΩΣΗ ΣΥΜΦΩΝΙΑΣ

Εμείς ως CALPEDA S.p.A. δηλώνουμε ότι οι αντλίες μας αυτές GXR, GXV, GXR-R, GXRM, GXVM, GXR-RM, με τύπο και αριθμό σειράς κατασκευής όπου αναγράφεται στην πινακίδα της αντλίας, κατασκευάζονται σύμφωνα με τις οδηγίες 2006/42/EOK, 2014/30/EU, 2014/35/EU και αναλαμβάνουμε πλήρη υπευθυνότητα για συμφωνία (συμμόρφωση), με τα στάνταρς των προδιαγραφών αυτών.

TR UYGUNLUK BEYANI

Bizler CALPEDA S.p.A. firması olarak GXR, GXV, GXR-R, GXRM, GXVM, GXR-RM, Pompalarımızın, 2006/42/EC, 2014/30/EU, 2014/35/EU, direktiflerine uygun olarak imal edildiıklarını beyan eder ve bu standartlara uygunluğuna dair tüm sorumluluğu üstleniriz.

RU ДЕКЛАРАЦИЯ СООТВЕТСТВИЯ

Компания "Calpeda S.p.A." заявляет с полной ответственностью, что насосы серий GXR, GXV, GXR-R, GXRM, GXVM, GXR-RM, тип и серийный номер которых указывается на заводской табличке соответствуют требованиям нормативов 2006/42/CE, 2014/30/EU, 2014/35/EU.

Il Presidente

Marco Mettifogo

Montorso Vicentino, 03.2018

 **calpeda**[®]

Calpeda s.p.a. - Via Roggia di Mezzo, 39 - 36050 Montorso Vicentino - Vicenza / Italia
Tel. +39 0444 476476 - Fax +39 0444 476477 - E.mail: info@calpeda.it www.calpeda.com